

IGBT

Features

- 1200V, 15A
- $V_{CE(sat)(typ.)}=2.2V@V_{GE}=15V, I_C=15A$
- High speed switching
- Higher system efficiency
- Soft current turn-off waveforms
- Square RBSOA using NPT technology

General Description

KEDA NPT IGBTs offer lower losses and higher energy efficiency for application such as IH (induction heating), UPS, general inverter and other soft switching applications.

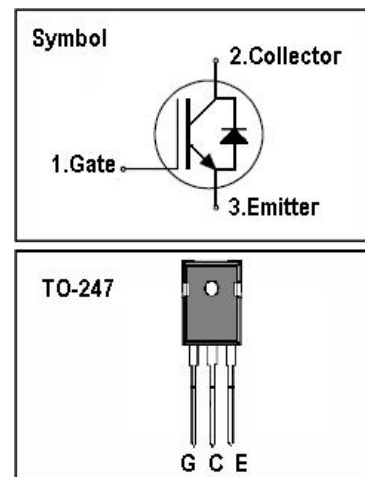

Absolute Maximum Ratings

Symbol	Parameter	Value	Units
V_{CES}	Collector-Emitter Voltage	1200	V
V_{GES}	Gate-Emitter Voltage	± 30	V
I_C	Continuous Collector Current ($T_C=25^\circ C$)	30	A
	Continuous Collector Current ($T_C=100^\circ C$)	15	A
I_{CM}	Pulsed Collector Current (Note 1)	60	A
I_F	Diode Continuous Forward Current ($T_C=100^\circ C$)	15	A
I_{FM}	Diode Maximum Forward Current (Note 1)	60	A
t_{sc}	Short Circuit Withstand Time	10	us
P_D	Maximum Power Dissipation ($T_C=25^\circ C$)	170	W
	Maximum Power Dissipation ($T_C=100^\circ C$)	68	W
T_J	Operating Junction Temperature Range	-55 to +150	$^\circ C$
T_{STG}	Storage Temperature Range	-55 to +150	$^\circ C$

Thermal Characteristics

Symbol	Parameter	Max.	Units
R_{thj-c}	Thermal Resistance, Junction to case for IGBT	0.51	$^\circ C/W$
R_{thj-c}	Thermal Resistance, Junction to case for Diode	0.85	$^\circ C/W$
R_{thj-a}	Thermal Resistance, Junction to Ambient	40	$^\circ C/W$

Electrical Characteristics ($T_C=25^\circ\text{C}$ unless otherwise noted)

Symbol	Parameter	Test Conditions	Min.	Typ.	Max.	Units
BV_{CES}	Collector-Emitter Breakdown Voltage	$V_{GE}=0V, I_C=250\mu A$	1200	-	-	V
I_{CES}	Collector-Emitter Leakage Current	$V_{CE}=1200V, V_{GE}=0V$	-	-	250	μA
I_{GES}	Gate Leakage Current, Forward	$V_{GE}=30V, V_{CE}=0V$	-	-	100	nA
	Gate Leakage Current, Reverse	$V_{GE}=-30V, V_{CE}=0V$	-	-	-100	nA
$V_{GE(th)}$	Gate Threshold Voltage	$V_{GE}=V_{CE}, I_C=250\mu A$	4.5	-	5.5	V
$V_{CE(sat)}$	Collector-Emitter Saturation Voltage	$V_{GE}=15V, I_C=15A$	-	2.2		V
Q_g	Total Gate Charge	$V_{CC}=960V$ $V_{GE}=15V$ $I_C=15A$	-	68		nC
Q_{ge}	Gate-Emitter Charge		-	22		nC
Q_{gc}	Gate-Collector Charge		-	23		nC
$t_{d(on)}$	Turn-on Delay Time	$V_{CC}=600V$ $V_{GE}=15V$ $I_C=15A$ $R_G=28\Omega$ Inductive Load $T_C=25^\circ\text{C}$	-	32	-	ns
t_r	Turn-on Rise Time		-	38	-	ns
$t_{d(off)}$	Turn-off Delay Time		-	223	-	ns
t_f	Turn-off Fall Time		-	74	-	ns
E_{on}	Turn-on Switching Loss		-	1.6	-	mJ
E_{off}	Turn-off Switching Loss		-	0.6	-	mJ
E_{ts}	Total Switching Loss		-	2.2	-	mJ
C_{ies}	Input Capacitance	$V_{CE}=25V$ $V_{GE}=0V$ $f=100\text{kHz}$	-	481	-	pF
C_{oes}	Output Capacitance		-	89	-	pF
C_{res}	Reverse Transfer Capacitance		-	28	-	pF
R_{gint}	Integrated gate resistor			3.8		Ω

Electrical Characteristics of Diode ($T_C=25^\circ\text{C}$ unless otherwise noted)

Symbol	Parameter	Test Conditions	Min.	Typ.	Max.	Units
V_F	Diode Forward Voltage	$I_F=15A$	-	2.0	2.4	V
t_{rr}	Diode Reverse Recovery Time	$V_{CE}=600V$ $I_F=15A$ $dI_F/dt=500A/\mu s$	-	110		ns
I_{rr}	Diode peak Reverse Recovery Current		-	16		A
Q_{rr}	Diode Reverse Recovery Charge		-	1060		nC

Notes:

1. Repetitive Rating: Pulse width limited by maximum junction temperature

Typical Performance Characteristics

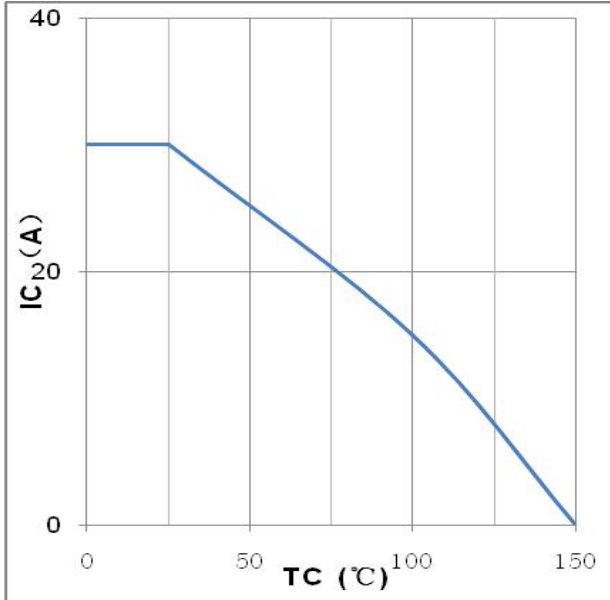

Figure1:maximum DC collector current VS. case temprature

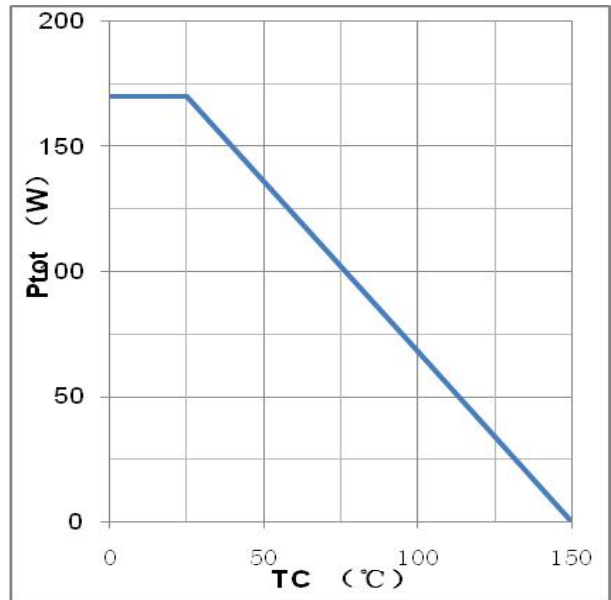

Figure2:power dissipation VS. case temprature

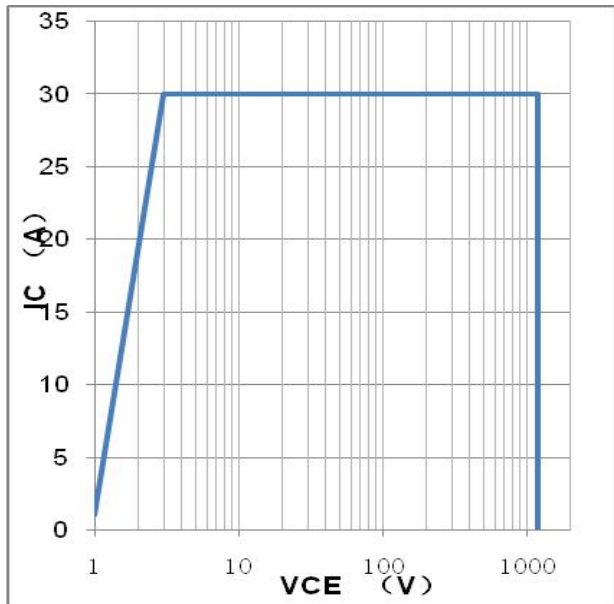

Figure3:reverse bias SOA,TJ=150°C,VGE=15V

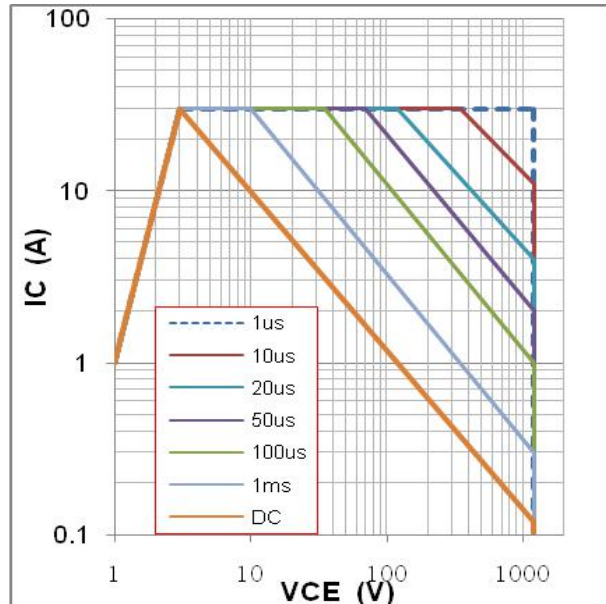

Figure4:forward SOA,TC=25°C,TJ≤150°C

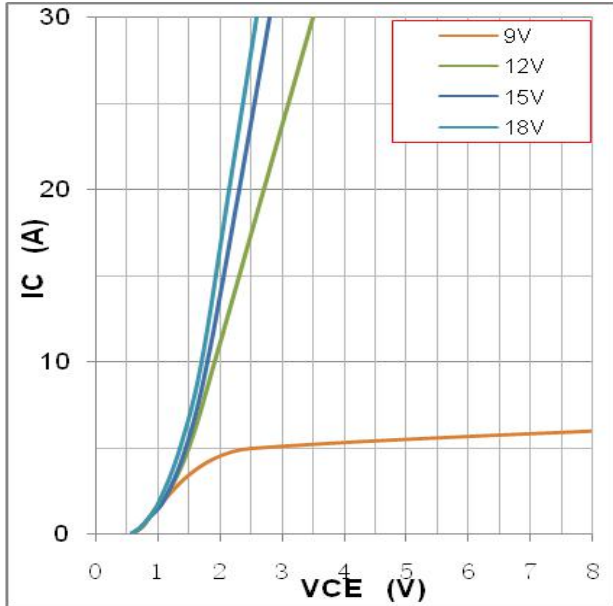

Figure5: typical IGBT output characteristics,
 $T_J=25^{\circ}\text{C}; t_p=300\mu\text{s}$

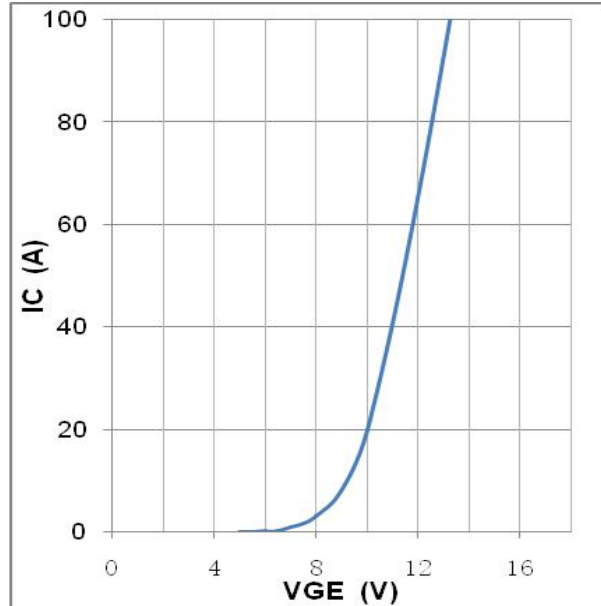

Figure6: typical trans characteristics, $V_{CE}=20\text{V}, t_p=20\mu\text{s}$

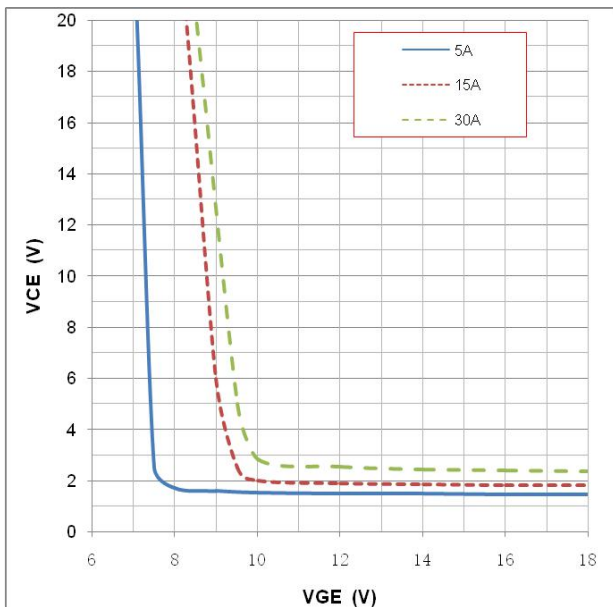

Figure7: typical VCE VS. VGE, $T_J=25^{\circ}\text{C}$

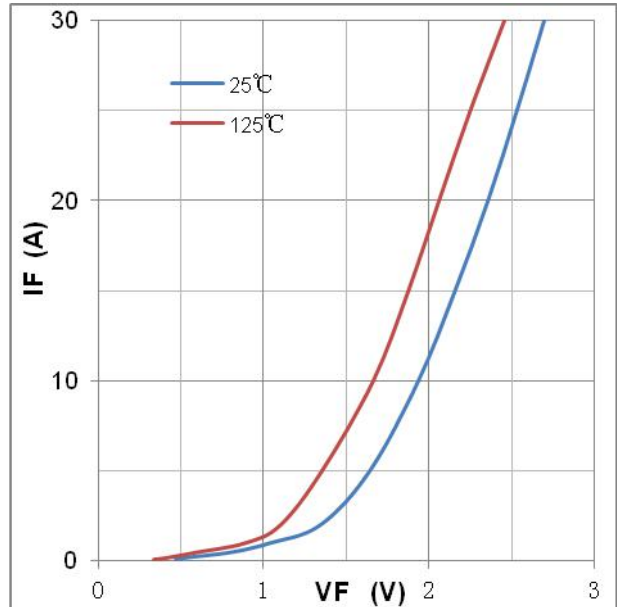

Figure8: typical diode forward characteristic, $t_p=300\mu\text{s}$

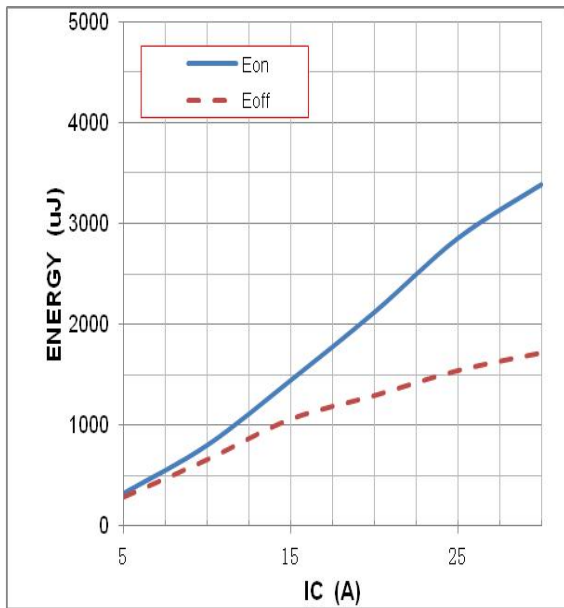

Figure9: typical energy loss VS. IC, TC=25°C,
L=500uH, VCE=600V, VGE=15V, Rg=28Ω,

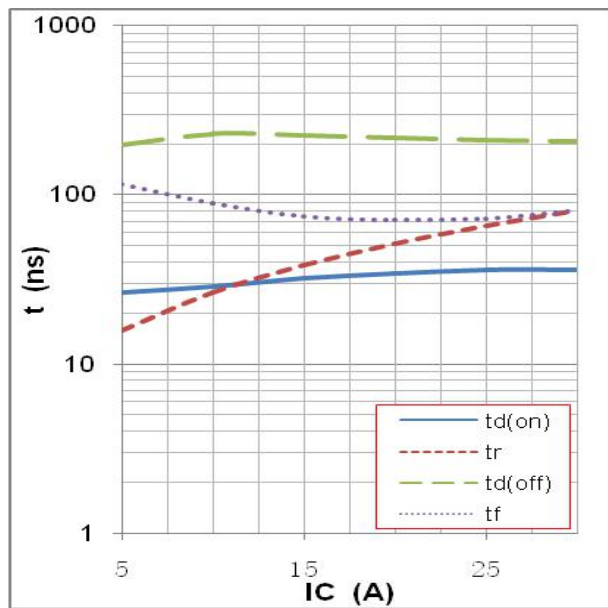

Figure10: typical switching time VS. IC, TC=25°C,
L=500uH, VCE=600V, VGE=15V, Rg=28Ω,

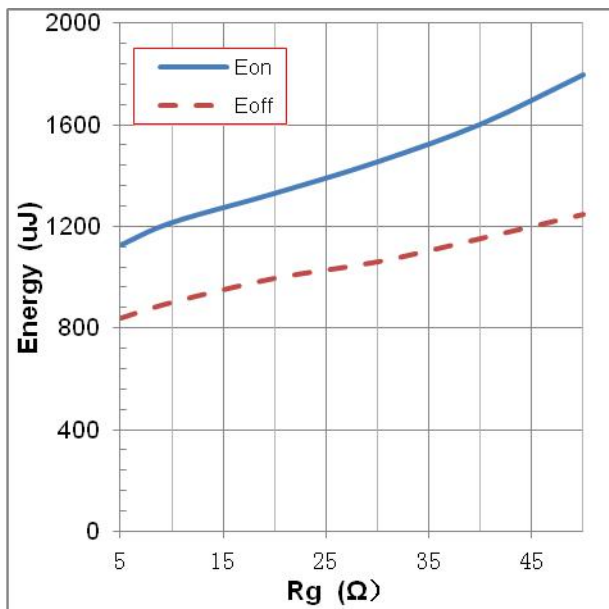

Figure11: typical energy loss VS. Rg, TC=25°C,
L=500uH, VCE=600V, VGE=15V, IC=15A

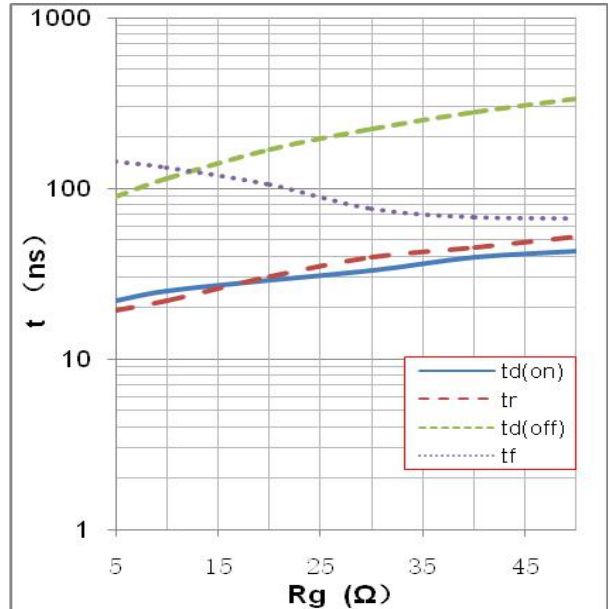

Figure12: typical switching time VS. Rg, TC=25°C,
L=500uH, VCE=600V, VGE=15V, IC=15A

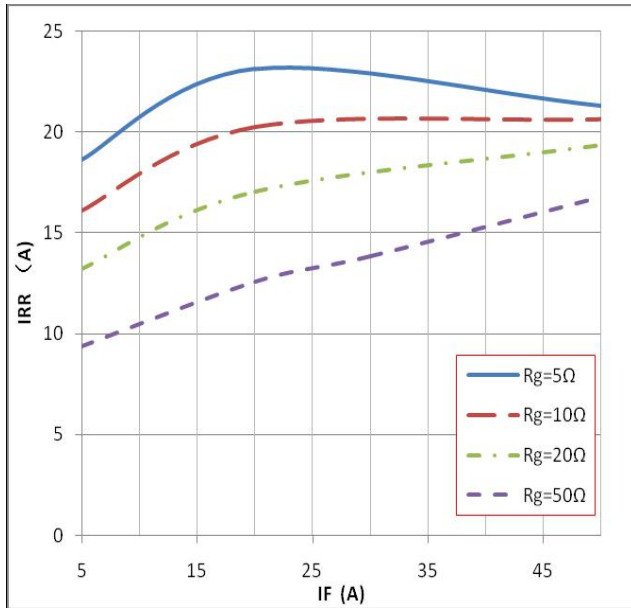

Figure13: typical diode IRR VS. IF, TC=25°C

VCC=600V, VGE=15V

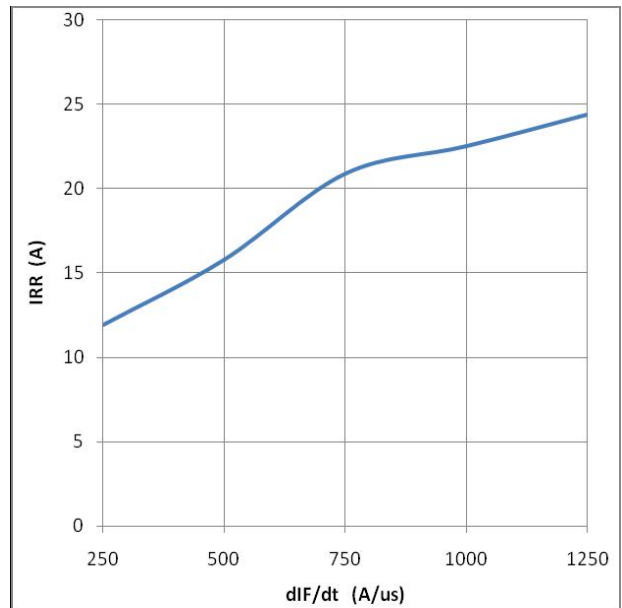

Figure14: typical diode IRR VS. dIF/dt

VCC=600V, VGE=15V IF=15A

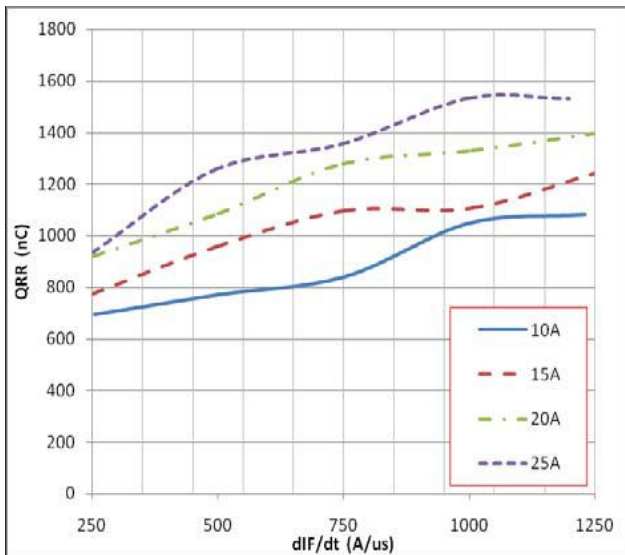

Figure15: typical diode QRR VS. dIF/dt

VCC=600V, VGE=15V

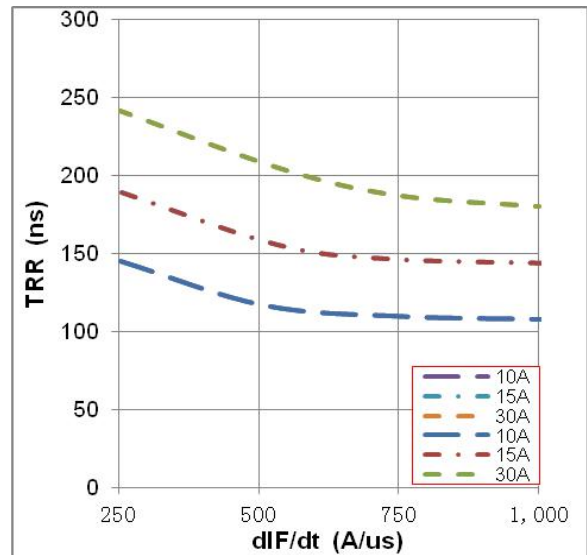

Figure16: typical diode TRR VS. dIF/dt,

VCC=600V, VGE=15V

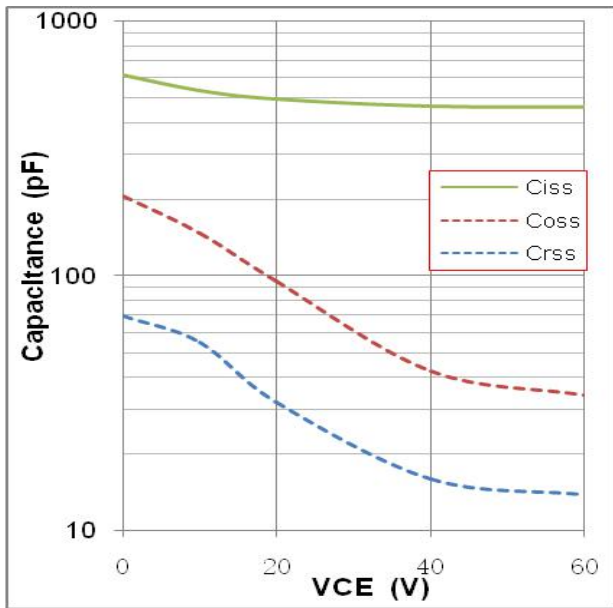

Figure17:typical capacitance VS. VCE,VGE=0V,f=100kHz

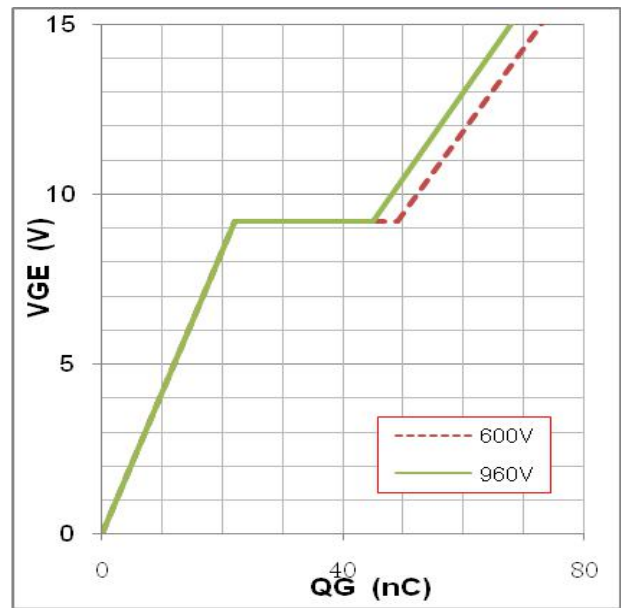

Figure18:typical gate charge VS. VGE,IC=15A

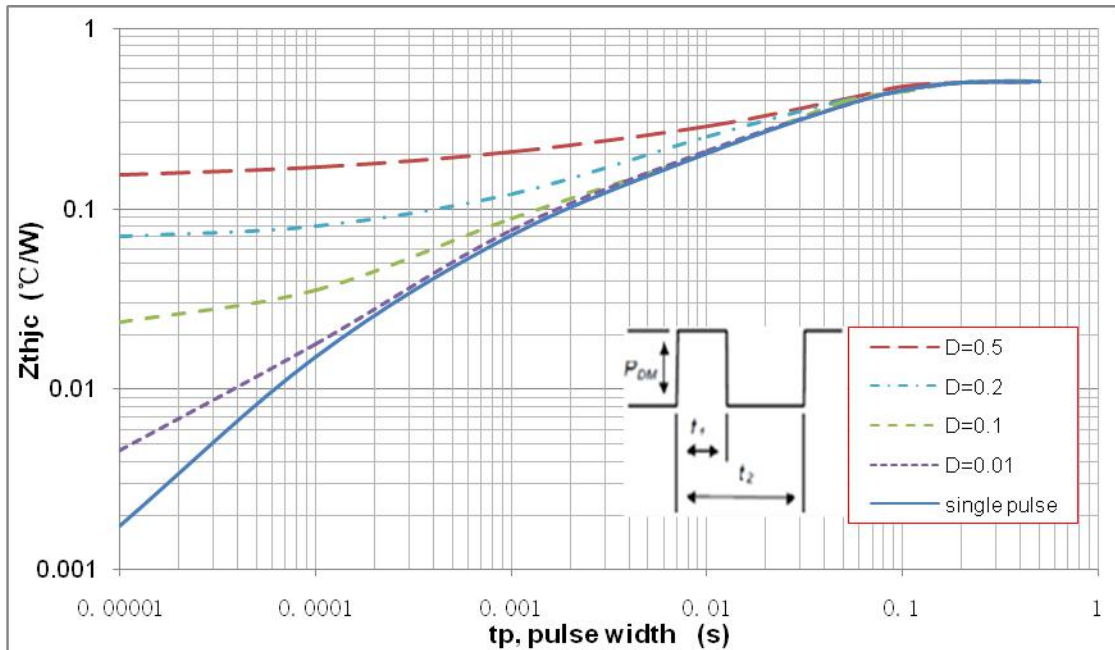
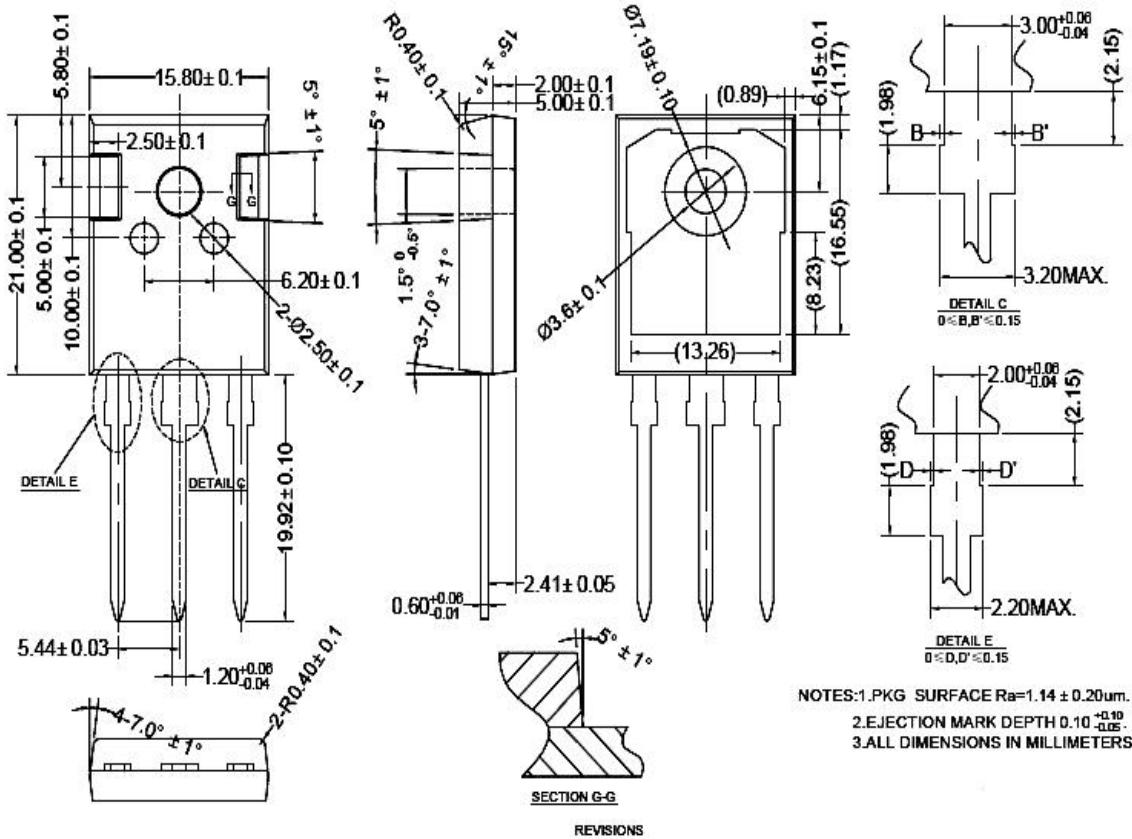

Figure19:normalised transient thermal impedance, junction-to-case

Note1.Duty factor $D=t_1/t_2$; Note2:peak $T_J=P_{DM} \times Z_{thjc} + T_C$

TO247 PACKAGE OUTLINE



NOTES: 1. PKG SURFACE Ra=1.14 ± 0.20um.
2. EJECTION MARK DEPTH 0.10 ^{+0.10}/_{-0.05}
3. ALL DIMENSIONS IN MILLIMETERS.

公差标注	公差值	表面粗糙度
0	±0.2	Ra3.2~6.3
0.0	±0.1	Ra1.6~3.2
0.00	±0.01	Ra0.8~1.6
0.000	±0.005	Ra0.4~0.8
0.0000	±0.002	Ra0.2~0.4

0 ≤ D, D' ≤ 0.15

NOTES: 1. PKG SURFACE Ra=1.14 ± 0.20um.
2. EJECTION MARK DEPTH 0.10 ^{+0.10}/_{-0.05}
3. ALL DIMENSIONS IN MILLIMETERS.